

Assembly instructions

for earthquake proof battery racks
1-row, 2-row and 2-step

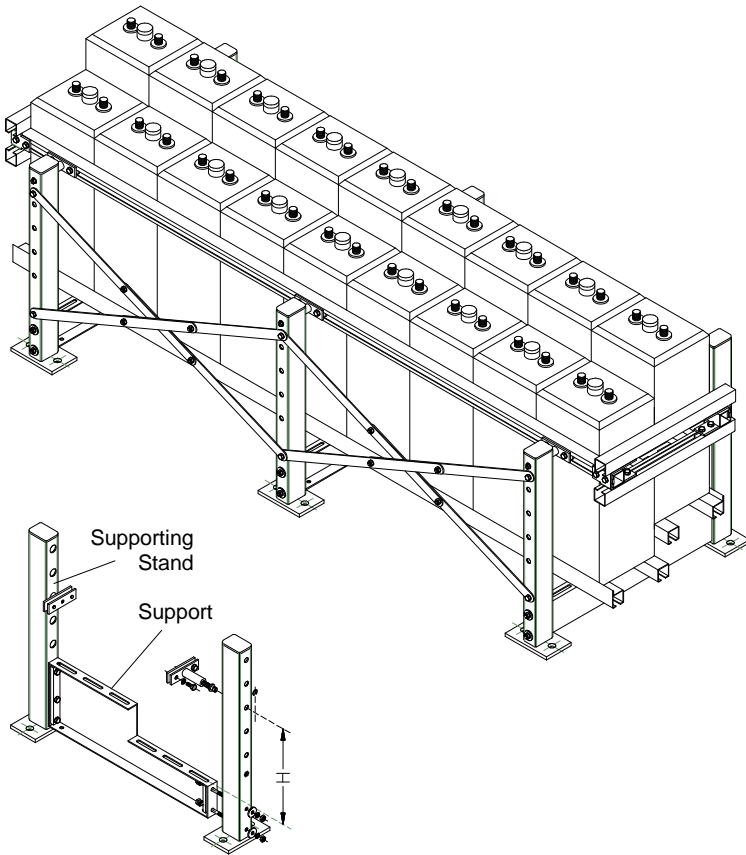

Assembling stands (uprights)

Firstly assemble and align supports and supporting stands (uprights).
In this connection, use screw M8x100, M8x25, washer 9/28, toothed lock washer and 2-hole and 3-hole plate.

Assembling the parts in the packet in this way will produce a pair of left and right stands.

The diagram shows a right stand with 2-stepped support.

The left stand mirrors the right stand.

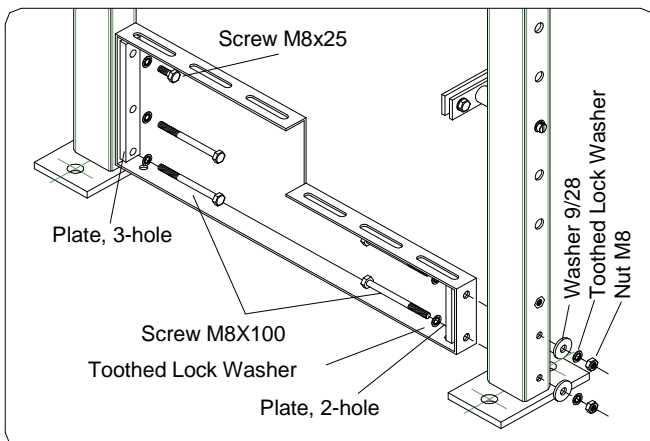

The screws M8x25 and 3-hole plates aren't needed for 1- and 2-row racks.

The order and sequence of assembly is the same for 1- or 2-row stands as it is for a 2 stepped stands.

NOTE

- Before you start with the assembly of the rack, check the packages delivered to ensure you have received the correct number and items.
- It is not possible to insert missing pieces at a later date.

HANDLE WITH CARE

- In case of coating damage, repair surface immediately

NOTE

- The rack system and the order of assembly is illustrated in the diagrams.

NOTE

- All screws must be tightened to a torque of 20 Nm [14.7 ft.lb].
- Do not over tighten.

Telescopes

Pre-assemble telescopes as illustrated in the diagram. Screw adjusting screw completely into flange shaft. Assemble connecting plate.

Connecting plate should be a distance of 8 mm from flange.

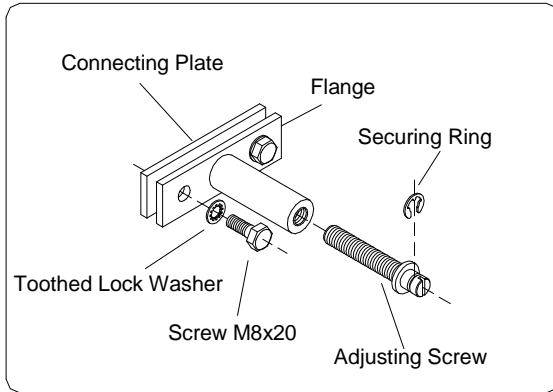

Insert telescopes in the stands from the inner side. Then secure with a securing ring.

When inserting the telescopes, select gap H. being the distance from there to the front part of the support, according to the height of the battery.

NOTE

- Gap H see table

Rack		Gap H from the front part of support
1- or 2-row battery height	2-step battery height	
160-270 [6.3"-10.6"	-	153 [6.0"] (1.hole)
270-420 [10.6"-16.5"	220-280 [8.7"-11.0"	228 [9.0"] (2.hole)
370-570 [14.6"-22.4"	280-370 [11.0"-14.6"	303 [12.0"] (3.hole)
450-720 [17.7"-28.3"	370-520 [14.6"-20.5"	378 [14.9"] (4.hole)
520-870 [20.5"-34.3"	520-670 [20.5"-26.4"	453 [17.8"] (5.hole)

Note: The values above are guide values. We recommend to adjust the retaining bar according to the battery (e.g. *min/ max level*).

Brace

For assembling each brace, use 2 screws M8x20, 4 toothed lock washer and 2 nuts M8.

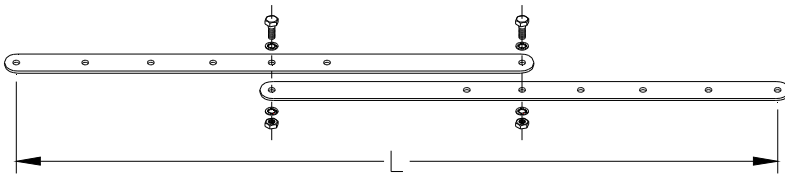

Length L is determined by the distance between the uprights. Measurements are listed in the table.

Center distance A of supports	Length L of brace
600 mm [23.62"	710 mm [27.95"
750 mm [29.52"	841 mm [33.11"
900 mm [35.43"	977 mm [38.46"
1050 mm [41.34"	1117 mm [43.98"
1200 mm [47.24"	1259 mm [49.57"
1350 mm [53.15"	1403 mm [55.24"
1500 mm [59.06"	1548 mm [60.94"

NOTE

- Length L see table

NOTE

- All screws must be tightened to a torque of 20 Nm [14.7 ft.lb].
- Do not over tighten.

Rack assembly

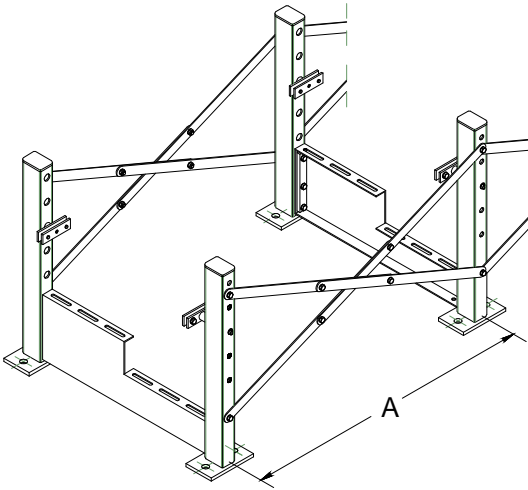

Place uprights in a vertical position and mount the brace according to distance A between the uprights, as defined in the enclosed diagram, and the respective distances A_1 , A_2 , A_3 ... and so on.

For assembling the braces, use screws M8x20, toothed lock washer and nuts M8.

NOTE

- Tighten all screws in upper lengthways and end rails to a torque of 20 Nm [14.7 ft.lb]
- Do not over tighten

Place frame in room and align.

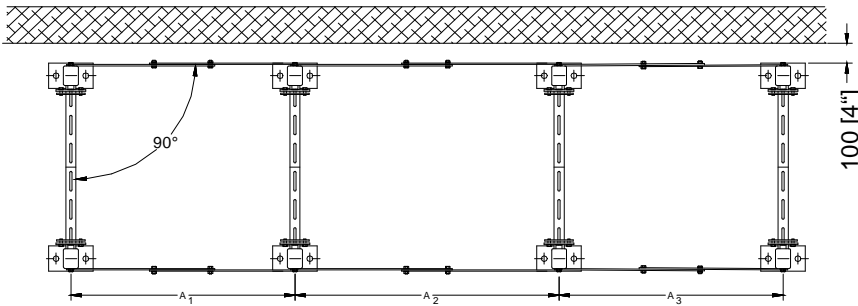

NOTE

Attention:

- Uprights must be at a right angle to the longitudinal axis of the frame.

The gap between the rack and the wall or other appliances in the room must be at least 100 mm [4"].

Mark screw points in the floor.

Drill holes for floor anchor bolts according to manufacturer's instructions. Insert anchor bolts and screw down frame.

NOTE

- Paying attention to torque for floor anchor bolts.

Assembling rails

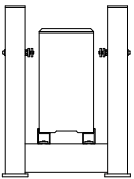

Assembly with a 1-row frame

- h-profiles are mounted in the center of the support, with a gap the width of the battery.

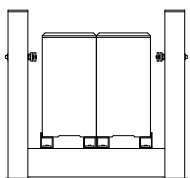

Assembly with a 2-tier or 2-stepped frame

- Firstly arrange two c-profiles close together in the center of the support, then mount an h-profile at a gap the width of the battery respectively.

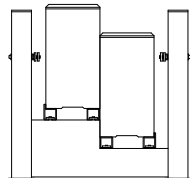

NOTE

- Paying attention to the battery width.

Mounting rails

Guide bolt M8x16 with washer 9/24 from below through the longitudinal hole in support, and screw it into the anchor plate

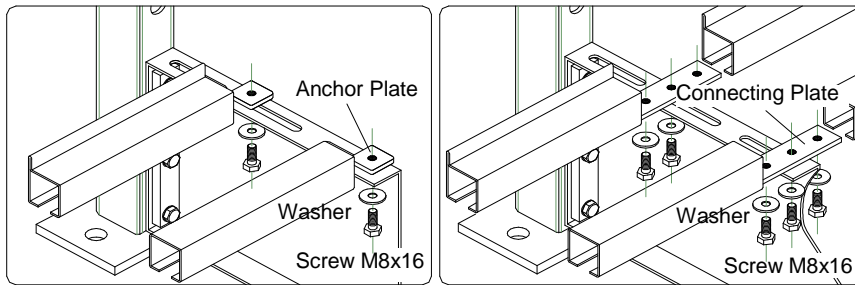

NOTE

- For frames which consist of more than one field, a connection plate must be used at the intersection of two rails.

NOTIZ

- All screws fixing the rails must be tightened to a torque of 8 Nm [5.6 ft.lb]
- Do not over tighten.

Inserting battery in rack

Insert batteries, cells and/or blocks.

Elements must be placed closely to one another.

The rails (h-profiles) must support the elements lengthways on the frame without room to maneuver. If necessary adjust the position of the h-profiles.

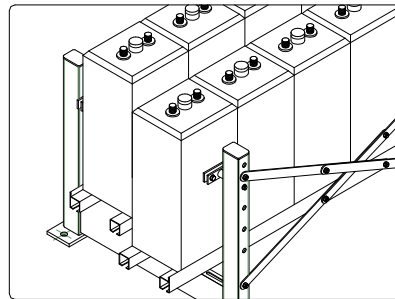

Note: Fill up the space between batteries with spacers (e.g. rib packing).

Inserting upper lengthways rails

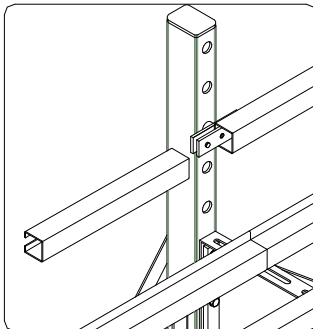

Insert upper lengthways rails and screw down tightly at intersections.

Adjust lengthways rails by means of the telescopic screw, until they lean against the battery.

NOTE

- The lengthways rails must touch but not exercise any pressure on the battery.

Inserting top end rails

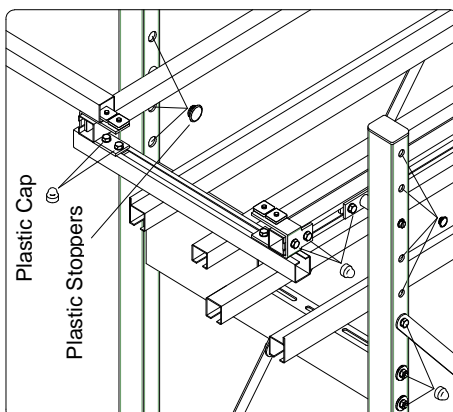

Pre-assemble holder. To this end use bolt M8x20 toothed lock washer and anchor plate.

Guide pre-assembled holder to the upper lengthways rails, as shown in the diagram.

Insert upper end rails, push them up to the battery and screw everything down. End rails must touch battery with no room for maneuver. If necessary, re-adjust end rails.

NOTE

- Tighten all screws in upper lengthways and end rails to a torque of 20 Nm [14.7 ft.lb]
- Do not over tighten
- Finally cover all screws with the plastic caps and close all openings in the stands with plastic stoppers